

30633 South Fraser Way
Abbotsford, BC

FOR LEASE

Airport North Business Park Office Building



Ideally suited for construction companies, construction related offices or any other Industrial office use. The building features bright sunny offices and has underground as well as grade level parking.



Fraser Valley Realty

Ken Neufeld

Business: 604.217.0455

Fax: 604.859.9200

www.abbotsfordicirealestate.com

kenneufeld@telus.net

Commercial Medallion Club

Lifetime Member
Award of Excellence
Diamond Award

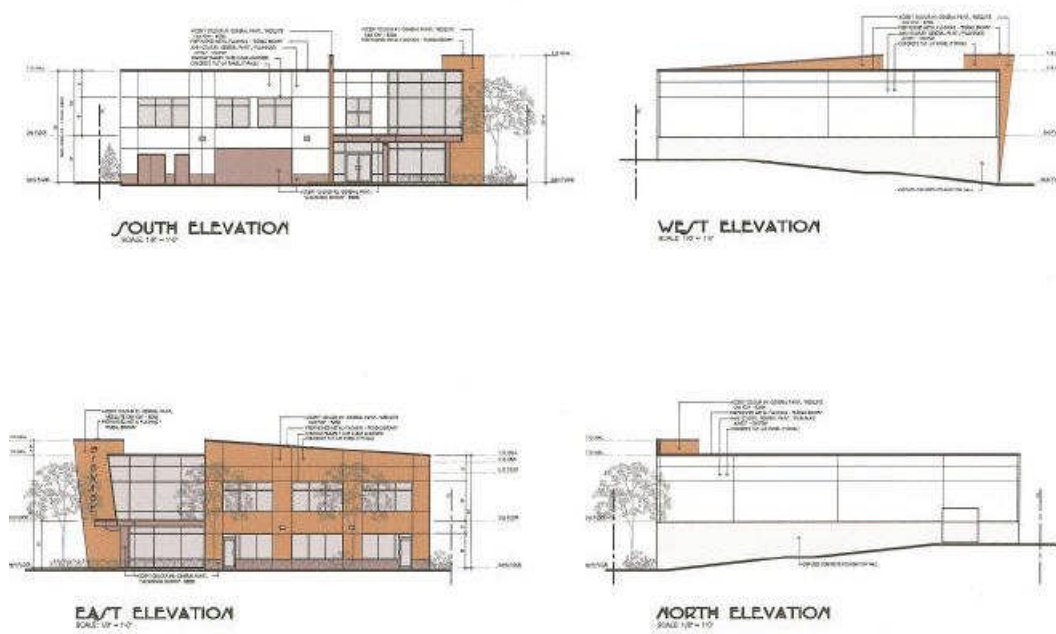

Abbotsford is a thriving, vibrant community that combines absolutely breathtaking views with every modern amenity. While it was once primarily an agriculture base community it has grown to become a real City offering everything desirable from farming to big business.

The City of Abbotsford is British Columbia's fifth largest City. It boasts a population estimate of 131,000 occupying a land mass of close to 90,000 acres. It is located just above the 49th parallel in an area known as the Fraser Valley. The closest border crossing to the U.S.A. is at Sumas, Washington and this is about a 10 minute drive from downtown Abbotsford. Vancouver is an hours drive away (70 km.) Chilliwack is located on the east boundary, Aldergrove/Langley on the West boundary and Mission to the North.

Ferry crossings to Vancouver Island are an easy drive and Whistler, the site of the 2010 Olympics, is about a 2 1/2 hours drive away. If flying is your transportation of choice, the Abbotsford International Airport is as handy as it gets with lots of parking, reasonable rates and easy access to Vancouver, points east or the U.S.A.

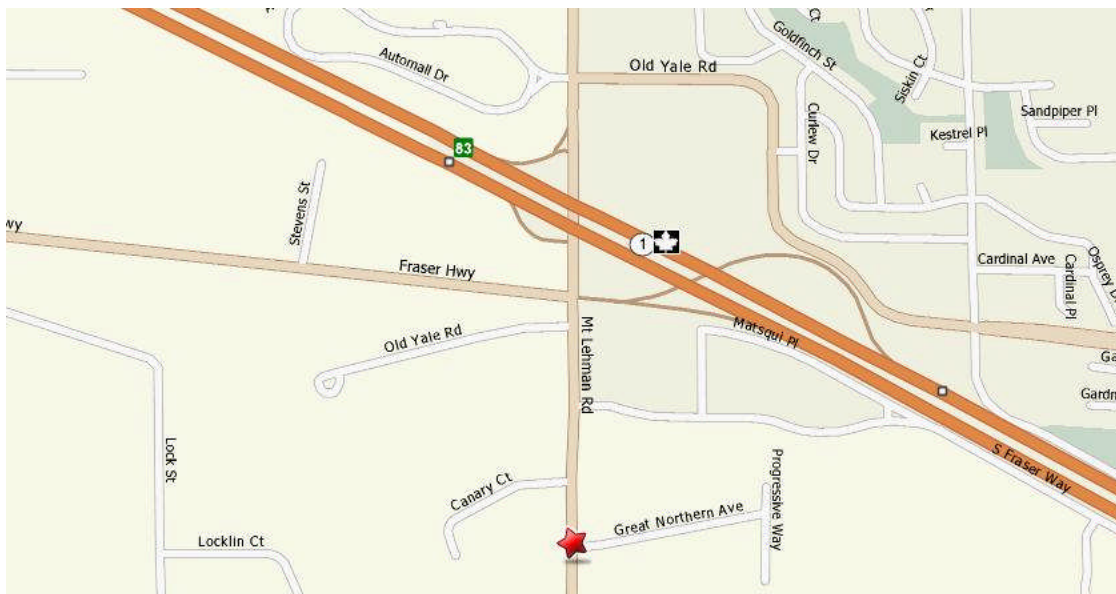

Ken Neufeld
 Business: 604.217.0455
 Fax: 604.859.9200
www.abbotsfordicirealestate.com
kenneufeld@telus.net

Commercial Medallion Club

Lifetime Member
 Award of Excellence
 Diamond Award

FOR LEASE

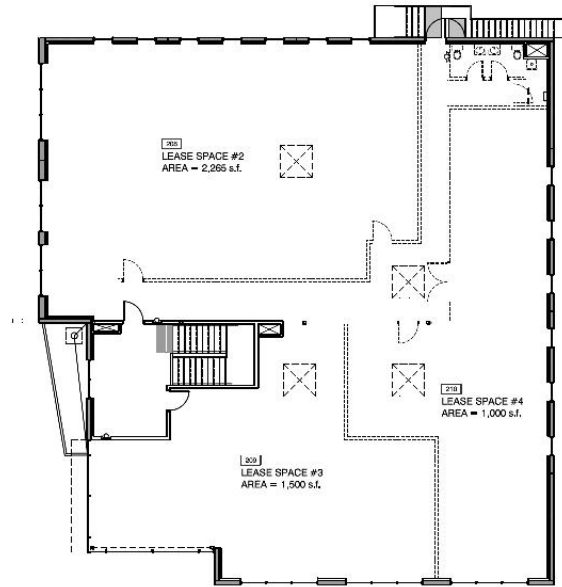

AIRPORT NORTH BUSINESS PARK - BUILDING #1

Features

Zoning

I-2 Office Industrial

Available for Lease Spring/Summer 2007

- *Three minutes from Abbotsford Airport and freeway entrance
- *Excellent road frontage on South Fraser Way
- *Ground floor office space available at \$16.75 per square foot, plus NNN
- *Second floor office space available at \$15.75 per square foot, plus NNN
- *Bright two story building
- *Underground parking
- *Access from Highway 1 East, Highway 1 West and the new Mt. Lehman Interchange

FOR FULL DETAILS VISIT THE WEBSITE BELOW



Fraser Valley Realty

Ken Neufeld

Business: 604.217.0455

Fax: 604.859.9200

www.abbotsfordicirealestate.com

kenneufeld@telus.net

Commercial Medallion Club

Lifetime Member
Award of Excellence
Diamond Award

First Floor

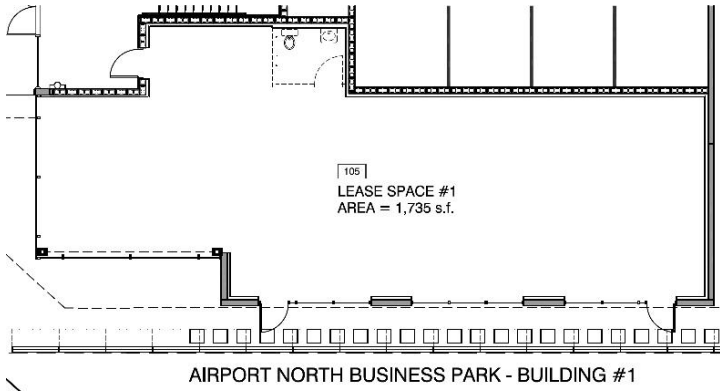

Second Floor

AIRPORT NORTH BUSINESS PARK - BUILDING #1

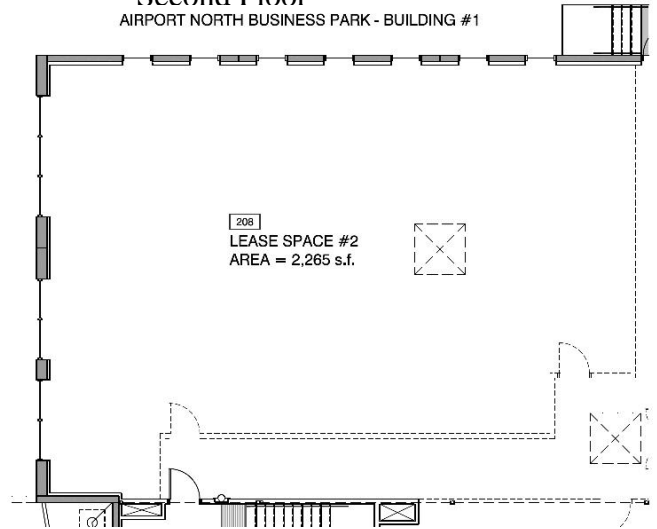

Second Floor

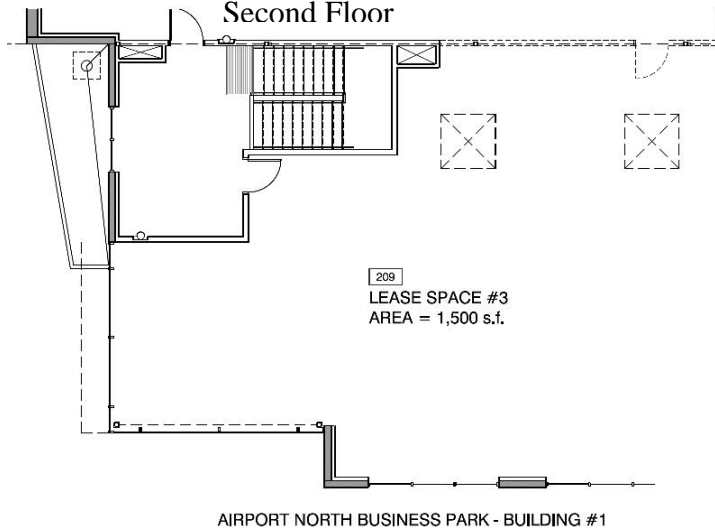

Second Floor

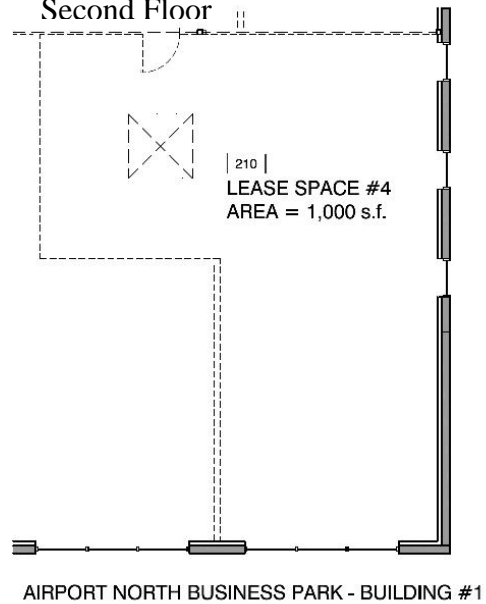

Brochure by Paragon Graphics



Ken Neufeld
 Business: 604.217.0455
 Fax: 604.859.9200
www.abbotsfordicirealestate.com
kenneufeld@telus.net

Commercial Medallion Club

Lifetime Member
 Award of Excellence
 Diamond Award